

Nucleoli as Maximizers of Collective Satisfaction Functions*

by Peter Sudhölter[†] Bezalel Peleg[‡]

January 1997

Abstract

Two preimputations of a given TU game can be compared via the Lorenz order applied to the vectors of satisfactions. One preimputation is ‘socially more desirable’ than the other, if its corresponding vector of satisfactions Lorenz dominates the satisfaction vector with respect to the second preimputation. It is shown that the prenucleolus, the anti-prenucleolus, and the modified nucleolus are maximal in this Lorenz order. Here the modified nucleolus is the unique preimputation which lexicographically minimizes the envies between the coalitions, i.e. the differences of excesses. Recently Sudhölter developed this solution concept. Properties of the set of all undominated preimputations, the maximal satisfaction solution, are discussed. A function on the set of preimputations is called collective satisfaction function if it respects the Lorenz order. We prove that both classical nucleoli are unique minimizers of certain ‘weighted Gini inequality indices’, which are derived from some collective satisfaction functions. For the (pre)nucleolus the function proposed by Kohlberg, who characterized the nucleolus as a solution of a single minimization problem, can be chosen. Finally, a collective satisfaction function is defined such that the modified nucleolus is its unique maximizer.

Key words: TU game, dual game, nucleolus, Lorenz order.

*We are grateful to two anonymous referees for some helpful remarks.

[†]Institute of Mathematical Economics, University of Bielefeld, Postfach 100131, D-33501 Bielefeld, Germany; **email:** psudhoelter@wiwi.uni-bielefeld.de

[‡]Center for Rationality and Interactive Decision Theory, The Hebrew University of Jerusalem, Feldman Building, Givat Ram, 91904 Jerusalem, Israel; **email:** pelegba@math.huji.ac.il

0 Introduction

Symmetry and fairness are among the basic tenets of the theory of solutions of cooperative games since its creation by von Neumann und Morgenstern (1944). Symmetry roughly means that a solution of a game must be invariant under the (linear transformations induced by the) symmetries of the game. (More general formulations are possible.) Fairness, or equal treatment, requires that at **each point** of the solution symmetric players receive equal payoffs. However, considerations of equity were not used to justify solutions of **transferable utility** (TU) games till the introduction of the nucleolus in Schmeidler (1969).

Schmeidler considered the distribution of excesses of coalitions (relative to a feasible payoff vector), and chose the feasible payoff vector that yields the minimum distribution (in the lexicographic order). Although Schmeidler was motivated by equity considerations, his approach is ad hoc and is not directly related to standard concepts of the theory of inequality (in economics). Indeed, Maschler (1992) writes on the definition of the nucleolus:

“Mathematicians will certainly admire the above definition, but can it be given a convincing intuitive meaning? Here is an attempt [Maschler, Peleg and Shapley (1979)]. Consider an arbitrator, whom the players ask to decide how to share $v(N)$. The arbitrator may regard the excess of a coalition as a measure of dissatisfaction and he may be eager to decrease the excesses of the various coalitions as much as possible. This will also increase “stability”. He will then look for payoffs in which the highest excess is as low as possible. If there is more than one such payoff, he will tell the highest-excess coalitions: “I have helped you as much as I could, but I can still help other coalitions.” He will then proceed to choose outcomes for which the second highest excess is minimal, and so on. Obviously, such “justification” raises more questions than it answers. What is more “stable”, a situation in which a few coalitions of highest excess have it as low as possible, or one where such coalitions have a slightly higher excess, but the excesses of many other coalitions are substantially lowered? It is the lexicographic order that is hard to motivate.”

Our paper addresses the foregoing questions raised by Maschler using the standard tools of equity theory. Let v be a TU game. With each preimputation of v (i.e., a Pareto optimal payoff vector) we associate the distribution of satisfactions of all the coalitions (the satisfaction of a coalition is the negative of its excess). We now compare preimputations by (partially) ordering their distributions of satisfactions by Lorenz domination. Our solution, the **maximal satisfaction solution** $\mathcal{M}(v)$, consists of the set of all preimputations whose distribution of satisfactions is maximal (i.e., it is not Lorenz dominated). It cannot be criticized in the foregoing manner, because it contains **all** equitable payoffs. Nonemptiness of $\mathcal{M}(v)$ is easily proved. We now briefly review the contents of the paper.

First we show that $\mathcal{M}(\cdot)$ has several standard properties: equal treatment, desirability, covariance, self duality (i.e., $\mathcal{M}(v) = \mathcal{M}(v^*)$ for each TU game v , where v^* is the dual of v), (strong) null player, and (two-sided) reasonableness. A second goal is to determine the structure of $\mathcal{M}(v)$ for each v . For this purpose we first obtain a geometric characterization of the points in $\mathcal{M}(v)$ (see Theorem 2.2). Then we prove that $\mathcal{M}(v)$ is a contractible union of a finite number of polytopes. $\mathcal{M}(v)$ is also a continuous function of the game v .

It is easily shown that the prenucleolus, the anti-prenucleolus, and the modified nucleolus are members of \mathcal{M} . Moreover, it follows from Kohlberg (1972) that the prenucleolus is the unique minimizer of some weighted Gini index. (We offer a purely geometric proof of this result (see Remark 3.3).) Kohlberg's result can be generalized to the modified nucleolus and the anti-prenucleolus. In the Appendix we give a new proof of Kohlberg's result. Our proof enables us to explicitly estimate the coefficients of Kohlberg's collective satisfaction function.

This first study of the maximal satisfaction solution leaves open many problems. We shall only mention one: To find a suitable axiomatization of $\mathcal{M}(\cdot)$.

1 Definitions and Preliminary Results

A **cooperative game with transferable utility** - a **game** - is a pair $G = (N, v)$, where N is a finite nonvoid set and

$$v : 2^N \rightarrow \mathbb{R}, \quad v(\emptyset) = 0$$

is a mapping. Here $2^N = \{S \subseteq N\}$ is the set of **coalitions** of G .

If $G = (N, v)$ is a game, then N is the **grand** coalition or the set of **players** and v is called **coalitional** (or **characteristic**) **function** of G . Since the nature of G is determined by the coalitional function, v is called game as well.

If $G = (N, v)$ is a game, then the **dual** game (N, v^*) of G is defined by

$$v^*(S) = v(N) - v(N \setminus S)$$

for all coalitions S . The set of **feasible payoff vectors** of G is denoted by

$$X^*(N, v) = X^*(v) = \{x \in \mathbb{R}^N \mid x(N) \leq v(N)\},$$

whereas

$$X(N, v) = X(v) = \{x \in \mathbb{R}^N \mid x(N) = v(N)\}$$

is the set of **preimputations** of G (also called set of **Pareto optimal** feasible payoffs of G). Here

$$x(S) = \sum_{i \in S} x_i \quad (x(\emptyset) = 0)$$

for each $x \in \mathbb{R}^N$ and $S \subseteq N$. Additionally, let x_S denote the restriction of x to S , i.e.

$$x_S = (x_i)_{i \in S} \in \mathbb{R}^S,$$

whereas $A_S = \{x_S \mid x \in A\}$ for $A \subseteq \mathbb{R}^N$. For disjoint coalitions $S, T \subseteq N$ and $x \in \mathbb{R}^N$ let $(x_S, x_T) = x_{S \cup T}$.

A **solution concept** σ on a set Γ of games is a mapping that associates with every game $v \in \Gamma$ a set $\sigma(v) \subseteq X^*(v)$.

If $\bar{\Gamma}$ is a subset of Γ , then the canonical restriction of a solution concept σ on Γ is a solution concept on $\bar{\Gamma}$. We say that σ is a solution concept on $\bar{\Gamma}$, too. If Γ is not specified, then σ is a solution concept on every set of games.

Some convenient and well-known properties of a solution concept σ on a set Γ of games are as follows.

- (1) σ is **anonymous** (satisfies **AN**), if for each $(N, v) \in \Gamma$ and each bijective mapping $\tau : N \rightarrow N'$ with $(N', \tau v) \in \Gamma$

$$\sigma(N', \tau v) = \tau(\sigma(N, v))$$

holds (where $(\tau v)(T) = v(\tau^{-1}(T))$, $\tau_j(x) = x_{\tau^{-1}j}$ ($x \in \mathbb{R}^N$, $j \in N'$, $T \subseteq N'$)).

In this case v and τv are **equivalent** games.

- (2) σ satisfies the **equal treatment property (ETP)**, if for every $x \in \sigma(N, v)$ ($v \in \Gamma$) interchangeable players $i, j \in N$ are treated equally, i.e. $x_i = x_j$. Here i and j are **interchangeable**, if $v(S \cup \{i\}) = v(S \cup \{j\})$ for $S \subseteq N \setminus \{i, j\}$.
- (3) σ **respects desirability** (satisfies **DES**) if for every $(N, v) \in \Gamma$ every $x \in \sigma(N, v)$ satisfies $x_i \geq x_j$ for a player i who is at least as desirable as player j . Here i is **at least as desirable** as j if $v(S \cup \{i\}) \geq v(S \cup \{j\})$ for $S \subseteq N \setminus \{i, j\}$.
- (4) σ satisfies the **nullplayer property (NPP)** if for every $(N, v) \in \Gamma$ every $x \in \sigma(N, v)$ satisfies $x_i = 0$ for every nullplayer $i \in N$. Here i is **nullplayer** if $v(S \cup \{i\}) = v(S)$ for $S \subseteq N$.
- (5) σ is **covariant under strategic equivalence** (satisfies **COV**), if $(N, v), (N, w) \in \Gamma$ with $w = \alpha v + \beta$ for some $\alpha > 0, \beta \in \mathbb{R}^N$ implies that

$$\sigma(N, w) = \alpha \sigma(N, v) + \beta$$

holds. The games v and w are called **strategically equivalent**.

- (6) σ is **single valued** (satisfies **SIVA**), if $|\sigma(v)| = 1$ for $v \in \Gamma$.
- (7) σ satisfies **nonemptiness (NE)**, if $\sigma(v) \neq \emptyset$ for $v \in \Gamma$.
- (8) σ is **Pareto optimal** (satisfies **PO**), if $\sigma(v) \subseteq X(v)$ for $v \in \Gamma$.
- (9) σ satisfies **reasonableness (on both sides) (REAS)**, if

(a)
$$x_i \geq \min\{v(S \cup \{i\}) - v(S) \mid S \subseteq N \setminus \{i\}\}$$

and

(b)
$$x_i \leq \max\{v(S \cup \{i\}) - v(S) \mid S \subseteq N \setminus \{i\}\}$$

for $i \in N, (N, v) \in \Gamma$, and $x \in \sigma(N, v)$.

Note that both equivalence and strategic equivalence commute with duality, i.e. $(\tau v)^* = \tau(v^*)$, $(\alpha v + \beta)^* = \alpha v^* + \beta$, where τ, α, β are chosen according to the definitions given above. With the help of assertion (9b) Milnor (1952) defined his notion of reasonableness.

It should be remarked (see Shapley (1953)) that the Shapley value φ (to be more precise the solution concept σ given by $\sigma(v) = \{\varphi(v)\}$) satisfies all above properties. Moreover, it is well-known that the Shapley value of a game and its dual cannot be distinguished. This observation motivates the following

Definition 1.1 *A solution concept σ on a set Γ of games is **self dual** (satisfies **SD**), if $\sigma(v) = \sigma(v^*)$ whenever $v, v^* \in \Gamma$.*

Some more notation will be needed. Let (N, v) be a game and $x \in \mathbb{R}^N$. The **excess of a coalition $S \subseteq N$ at x** is the real number

$$e(S, x, v) = e(S, x) = v(S) - x(S).$$

The **satisfaction of a coalition S at x** is the negative excess of S , denoted by $f(S, x, v) = f(S, x) = x(S) - v(S)$.

To a ‘utility’ vector $x \in \mathbb{R}^N$ its **Lorenz curve** $L(x) = y \in \mathbb{R}^n$, where $n = |N|$, defined by

$$y_k = \min\{x(S) \mid S \subseteq N \text{ and } |S| = k\} \text{ for } k \in \{1, \dots, n\},$$

is attached. If the points $(k, L_k(x))$ are plotted and consecutive points $(k, L_k(x)), (k+1, L_{k+1}(x))$ are connected by a line segment, then a **curve** is obtained (see Fig. 4.1). A **collective utility function** is a continuous mapping $W : \mathbb{R}^N \rightarrow \mathbb{R}$ which satisfies

- (1) Anonymity: $W(x) = W(y)$, if x arises from y by a permutation of the components, and
- (2) Unanimity: $W(x) \geq W(y)$, if $x \geq y$, and $W(x) > W(y)$, if $x_i > y_i$ for $i \in N$

for $x, y \in \mathbb{R}^N$.

To simplify notation we define x^\bullet to be the vector which arises from x by ordering the components of x nondecreasingly, i.e.

$$\sum_{i=1}^k x_i^\bullet = L_k(x) \text{ for every } k \in \{1, \dots, n\}.$$

A collective utility function W is said to **reduce inequality**, if W respects Lorenz domination, i.e. if $L(x) \geq L(y)$ and $L(x) \neq L(y)$ hold (x **Lorenz dominates** y), then $W(x) > W(y)$ is valid. For this notation Moulin (1988) is referred to.

In order to compare feasible payoff vectors of a game in terms of their satisfaction vectors it is sufficient to replace ‘utility’ by ‘satisfaction’. The formal notion is given in

Definition 1.2 *Let (N, v) be a game and $x, y \in X^*(v)$.*

(1) x **dominates** y via satisfaction w.r.t. v (written $x \succ_v y$), if

$$(f(S, x, v))_{S \subseteq N} \text{ Lorenz dominates } (f(S, y, v))_{S \subseteq N}.$$

We write $x \succeq_v y$, if x **weakly dominates** y via satisfaction, i.e. if either $x \succ_v y$ or $L((f(S, x, v))_{S \subseteq N}) = L((f(S, y, v))_{S \subseteq N})$.

(2) Let $\mathcal{D}(x, v) = \{z \in X^*(v) \mid z \succ_v x\}$ be the set of feasible payoff vectors which dominate x via satisfaction. The set of weakly dominating vectors is denoted by $\bar{\mathcal{D}}(x, v) = \{z \in X^*(v) \mid z \succeq_v x\}$.

(3) x **maximizes satisfaction** w.r.t. v , if $\mathcal{D}(x, v) = \emptyset$. Let $\mathcal{M}(v) = \{z \in X^*(v) \mid z \text{ maximizes satisfaction w.r.t. } v\}$ be the set of feasible payoff vectors which are not dominated via satisfaction.

Note that x weakly dominates y via satisfaction w.r.t. (N, v) , if

$$\sum_{S \in \mathcal{S}} f(S, x, v) \geq \min \left\{ \sum_{S \in \mathcal{T}} f(S, y, v) \mid \mathcal{T} \subseteq 2^N, |\mathcal{T}| = k \right\} \quad (1.1)$$

for every $k = 1, \dots, 2^n$ and every subset $\mathcal{S} \subseteq 2^N$ with $|\mathcal{S}| = k$. Moreover, x dominates y , if additionally one of the equations (1.1) is strict.

Lemma 1.3 *If (N, v) is a game and $x \in X^*(v)$, then $\bar{\mathcal{D}}(x, v)$ is a nonempty convex compact set.*

Proof: Nonemptiness and boundedness are guaranteed by the facts that $x \in \bar{\mathcal{D}}(x, v)$ and $f(S, y, v) \geq \min_{T \subseteq N} f(T, x, v)$ for every $S \subset N$ and $y \in \bar{\mathcal{D}}(x, v)$ hold true. Convexity is a direct consequence of the fact that every component $L_k((f(S, \cdot, v))_{S \subseteq N}) : X^*(v) \rightarrow \mathbb{R}$ of the Lorenz curve of the satisfaction vector is a minimum of finitely many affine linear functions and, thus, concave. Continuity of these component functions guarantees closedness of $\bar{\mathcal{D}}(x, v)$. q.e.d.

In order to show that the set of vectors which weakly dominate x intersects $\mathcal{M}(v)$ we recall the definition of a nucleolus. For $X \subseteq \mathbb{R}^N$ the **nucleolus** of v w.r.t. X is the set $\mathcal{N}(X, v)$ of vectors in X which lexicographically minimize the nonincreasingly ordered vector of excesses, i.e.

$$\mathcal{N}(X, v) = \{x \in X \mid -G^\bullet(x) \leq_{lex} -G^\bullet(y) \text{ for } y \in X\},$$

where $G(x) = ((f(S, x, v))_{S \subseteq N})$. Schmeidler (1969) showed that nonemptiness together with compactness of X implies nonemptiness of the nucleolus, whereas convexity of X implies that $\mathcal{N}(X, v)$ contains **at most** one element.

Corollary 1.4 $\mathcal{M}(v) \cap \bar{\mathcal{D}}(x, v)$ is nonempty for every game (N, v) and every feasible payoff vector $x \in X^*(v)$.

Proof: By definition $\mathcal{N}(\bar{\mathcal{D}}(x, v), v) \subseteq \mathcal{M}(v)$, thus Lemma 1.3 completes the proof. q.e.d.

Further properties of \mathcal{M} are summarized in the following

Lemma 1.5 *On every set Γ of games the solution concept \mathcal{M} satisfies (1) AN, (2) ETP, (3) DES, (4) COV, (5) PO, and (6) SD.*

Proof: It is straightforward to verify AN and COV. ETP is a direct consequence of DES. Therefore it is sufficient to show PO, DES, and SD.

(5) Let $(N, v) \in \Gamma$ and $x \in X^*(v)$. If x is not a preimputation, then there exists $\epsilon > 0$ such that y , defined by $y_i = x_i + \epsilon$ for $i \in N$ belongs to $X^*(v)$. Clearly $f(S, x, v) < f(S, y, v)$ for $\emptyset \neq S \subseteq N$ holds true, thus y dominates x via satisfaction. Note that ϵ can be chosen in such a way that y is a preimputation.

(3) In view of Pareto optimality which is established for \mathcal{M} we assume that $x \in X(v)$. Take $i, j \in N$ and assume that i is at least as desirable as j . If $x_i < x_j$, take $\epsilon > 0$ such that y , defined by

$$y_k = \begin{cases} x_k & , \text{ if } k \in N \setminus \{i, j\} \\ x_i + \epsilon & , \text{ if } k = i \\ x_j - \epsilon & , \text{ if } k = j \end{cases} ,$$

satisfies $y_i \leq y_j$. By definition of y and assumption we come up with $f(S, x, v) = f(S, y, v)$ and

$$f(S \cup \{i\}, x, v) + \epsilon = f(S \cup \{i\}, y, v) \leq f(S \cup \{j\}, y, v) = f(S \cup \{j\}, x, v) - \epsilon$$

for every coalition $S \subseteq N \setminus \{i, j\}$. Thus y dominates x .

(6) Let $(N, v), (N, v^*) \in \Gamma$ and $x \in \mathcal{M}(v)$. For every $S \subseteq N$

$$f(S, x, v) = -f(N \setminus S, x, v^*) \tag{1.2}$$

is true by Pareto optimality (see (5)). Assume, on the contrary there is $y \in X^*(v^*)$ which dominates x via satisfaction w.r.t. v^* . Then y can be assumed to be Pareto optimal w.r.t. v^* and, hence, w.r.t. v . Equation 1.2 together with the fact that the sum of all satisfactions is constant on the set of preimputations shows that $y \succ_v x$ (because

$$L_k((f(S, z, v^*))_{S \subseteq N}) = L_{2^n - k}((f(S, z, v))_{S \subseteq N}) - L_{2^n}((f(S, x, v))_{S \subseteq N})$$

(where $L_0(\cdot) = 0$ by convention) is true for $z \in X(v)$), thus a contradiction is established. q.e.d.

Though we have seen that the nucleolus of v w.r.t. the set of elements which weakly dominate x (for every feasible payoff vector x of v) via satisfaction is a singleton contained in the set of undominated preimputations it should be noted that both the **prenucleolus** $\mathcal{N}(X^*(v), v) = \{\nu(v)\}$ as well as the **antinucleolus** $\nu^*(v) = \nu(v^*)$ of v are members of the **maximal satisfaction solution** $\mathcal{M}(v)$. Indeed, $\nu(v)$ must be a member of the maximal satisfaction solution applied to v , which can be seen directly, whereas the antinucleolus must be a member of $\mathcal{M}(v)$ by Lemma 1.5 (6).

Remark 1.6

- (1) Note that the maximal satisfaction solution is a **standard solution** which means that for 2-person games (N, v) , let us say $N = \{i, j\}$, the only member of $\mathcal{M}(v)$ assigns $[v(\{i\}) - v(\{j\}) + v(N)]/2$ to player i . NE, PO, ETP, and COV imply this property.
- (2) In what follows an example is presented which simultaneously shows that $\mathcal{M}(v)$ is not necessarily convex (though it is a finite union of polytopes as proved in the next section) and does not necessarily contain the Shapley value. To this end let (N, v) be defined by $N = \{1, \dots, 4\}$ and

$$v(S) = \begin{cases} 12 & , \text{ if } S \in \{\{4\}, \{3, 4\}, \{2, 3\}, \{1, 3, 4\}, N\} \\ 0 & , \text{ otherwise} \end{cases} .$$

With the help of Kohlberg's (1971) characterization of the prenucleolus by balanced collections of coalitions it can easily be checked that

$$\nu(v) = (-4, 2, 6, 8) \text{ and } \nu^*(v) = (4, 0, 4, 4).$$

Moreover, the Shapley value can be computed as $\varphi(v) = (1, -1, 5, 7)$. The verification that $(1, -1, 6, 6) \succ_v \varphi(v)$ and $(0, 0, 6, 6) \succ_v (\nu(v) + \nu^*(v))/2$ is straightforward and left to the reader.

- (3) The maximal satisfaction solution need not be contained in the core even for convex games. (Recall that a game (N, v) is convex, if $v(S) + v(T) \leq v(S \cup T) + v(S \cap T)$ for all $S, T \subseteq N$.) Indeed, Sudhölter (1997, Example 3.2(iii)) presented a convex five-person game v such that the core of v does not contain the antinucleolus $\nu(v^*)$ which is a member of $\mathcal{M}(v)$.
- (4) The following example shows that the egalitarian solution (as defined by Dutta and Ray (1989)) need not be contained in the maximal satisfaction solution even for convex games. Let (N, v) be the convex three-person game defined by $N = \{1, 2, 3\}$ and

$$v(S) = \begin{cases} 6 & , \text{ if } 1 \in S \text{ and } |S| = 2 \\ 12 & , \text{ if } S = N \\ 0 & , \text{ otherwise} \end{cases} .$$

Then the maximal satisfaction solution is a singleton consisting of the unique vector $(6, 3, 3)$ (which is simultaneously the nucleolus, the anti-prenucleolus, and the Shapley value), whereas the egalitarian solution is the ‘equal split’ vector $(4, 4, 4)$.

2 Characterizations of the Maximal Satisfaction Solution

This section serves to present characterizations of $\mathcal{M}(v)$ which allow many applications. Indeed, as a byproduct we show that this solution concept satisfies the **strong** nullplayer property which can be used to verify REAS. Moreover, $\mathcal{M}(v)$ turns out to be a contractible finite union of compact polytopes.

Some notation is needed. During this section let N be a finite set of at least two elements. Recall that a finite set $X \subseteq \mathbb{R}^N$ is **balanced**, if it possesses **balancing coefficients** $(\delta_x)_{x \in X}$, i.e.

$$\delta_x > 0 \text{ for } x \in X \text{ and } \sum_{x \in X} \delta_x x = 1_N.$$

Here 1_N is the vector $(1, \dots, 1) \in \mathbb{R}^N$ as usual.

Definition 2.1 Let (N, v) be a game and $x \in X^*(v)$.

- (1) A finite sequence $\mathcal{G} = (\mathcal{G}_j)_{j=1}^r$ of collections of coalitions is a **configuration of N** , if

$$\sum_{j=1}^r |\mathcal{G}_j| = 2^n - 2 \text{ and } \bigcup_{j=1}^r \mathcal{G}_j = 2^N \setminus \{\emptyset, N\}.$$

Moreover, $\mathcal{G}_j \neq \emptyset$ is assumed for $1 \leq j \leq r$.

- (2) A configuration $\mathcal{G} = (\mathcal{G}_j)_{j=1}^r$ of N **generates** the subset

$$X(\mathcal{G}) = \left\{ \sum_{j=1}^k \sum_{S \in \mathcal{G}_j} 1_S + \sum_{S \in \mathcal{T}} 1_S \mid k = 0, \dots, r-1, \mathcal{T} \subseteq \mathcal{G}_{k+1} \right\}.$$

- (3) A configuration \mathcal{G} of N is **feasible**, if $X(\mathcal{G})$ is balanced.

- (4) The feasible payoff vector x **induces** the configuration $\mathcal{G}(x, v) = (\mathcal{G}_j)_{j=1}^r$ defined by

- (a) $f(S, x, v) = f(T, x, v)$ for $S, T \in \mathcal{G}_j$ and $j = 1, \dots, r$;
- (b) $f(S, x, v) < f(T, x, v)$ for $S \in \mathcal{G}_j, T \in \mathcal{G}_{j+1}$ and $1 \leq j < r$.

Theorem 2.2 Let $x \in X(v)$ for some game (N, v) . The preimputation x of v maximizes satisfaction, if and only if the induced configuration $\mathcal{G}(x, v)$ is feasible.

This Theorem is a direct consequence of the duality theorem of linear programming and the following

Lemma 2.3 Let $x \in X(v)$ for some game (N, v) and

$$Y = \{y \in \mathbb{R}^N \mid y(N) = 0 \text{ and } y \cdot z \geq 0 \text{ for every } z \in X(\mathcal{G}(x, v))\}.$$

Then $x \in \mathcal{M}(v)$, if and only if $Y = \{(0, \dots, 0)\}$.

Proof: Let $x \in X(v)$. Clearly, $(0, \dots, 0) \in Y$.

- (1) In order to show that $Y = \{(0, \dots, 0)\}$ implies $x \in \mathcal{M}(v)$, assume there is a preimputation $x \in X(v) \setminus \mathcal{M}(v)$, which does not maximize satisfaction, and choose some preimputation $x' \in X(v)$ satisfying $x' \succ_v x$; thus $x' \neq x$ is valid. It remains to show that $x' - x$ is a member of Y . For

$$z = \sum_{j=1}^t \sum_{S \in \mathcal{G}_j(x, v)} 1_S + \sum_{S \in \mathcal{T}} 1_S \in X(\mathcal{G}(x, v)), \quad T \subseteq \mathcal{G}_{t+1}(x, v)$$

inequality (1.1) (applied to x' and x instead of x and y) implies

$$\begin{aligned} & zx' - \sum_{j=1}^t \sum_{S \in \mathcal{G}_j(x, v)} v(S) - \sum_{S \in \mathcal{T}} v(S) \\ &= \sum_{j=1}^t \sum_{S \in \mathcal{G}_j(x, v)} f(S, x', v) + \sum_{S \in \mathcal{T}} f(S, x', v) \\ &\geq \min\left\{ \sum_{S \in \mathcal{S}} f(S, x, v) \mid |\mathcal{S}| = \sum_{j=1}^t |\mathcal{G}_j(x, v)| + |\mathcal{T}| \right\} \\ &= zx - \sum_{j=1}^t \sum_{S \in \mathcal{G}_j(x, v)} v(S) - \sum_{S \in \mathcal{T}} v(S), \end{aligned}$$

hence $z(x' - x) \geq 0$. Therefore $x' - x \in Y$ holds true.

- (2) In order to show the converse implication, assume there is $y \in Y$ satisfying $y \neq 0$. For every real number ϵ define $x^\epsilon = x + \epsilon y$. Choose $\epsilon > 0$ small enough such that for every pair $S, T \subseteq N$ of coalitions satisfying $f(S, x, v) < f(T, x, v)$ the condition

$$f(S, x^\epsilon, v) < f(T, x^\epsilon, v) \tag{2.1}$$

is also satisfied.

For $k \in \{1, \dots, 2^n\}$ let $\min\{\sum_{S \in \mathcal{S}} f(S, x^\epsilon, v) \mid |\mathcal{S}| = k\}$ be attained by a collection \mathcal{S}^k of cardinality k of coalitions. The collections \mathcal{S}^k can be chosen in an increasingly ordered way, i.e.

$$\emptyset \subset \mathcal{S}^1 \subset \dots \subset \mathcal{S}^{2^n} = 2^N \tag{2.2}$$

can be assumed. Then

$$\min\left\{ \sum_{S \in \mathcal{S}} f(S, x, v) \mid |\mathcal{S}| = k \right\} = \sum_{S \in \mathcal{S}^k} f(S, x, v)$$

holds true by (2.1). Moreover, in view of the definition of $\mathcal{G}(x, v)$, there is a number t^k and a set $\mathcal{T}^k \subseteq \mathcal{G}_{t^k+1}(x, v)$ of coalitions satisfying

$$\mathcal{S}^k = \bigcup_{j=1}^{t^k} \mathcal{G}_j(x, v) \cup \mathcal{T}^k.$$

With

$$z^k = \sum_{j=1}^{t^k} \sum_{S \in \mathcal{G}_j} 1_S + \sum_{S \in \mathcal{T}^k} 1_S \in X(\mathcal{G}(x, v))$$

we conclude that

$$\min\left\{\sum_{S \in \mathcal{S}} f(S, x^\epsilon, v) \mid |\mathcal{S}| = k\right\} = \min\left\{\sum_{S \in \mathcal{S}} f(S, x, v) \mid |\mathcal{S}| = k\right\} + \epsilon y z^k,$$

thus $x^\epsilon \succeq_v x$. The fact that the vectors z^k span the Euclidean space is a straightforward consequence of (2.2). Therefore $y z^k > 0$ for some k by $y \neq 0$, thus $x^\epsilon \succ_v x$ is satisfied. q.e.d.

Remark 2.4

- (1) Similarly to Part (1) of the preceding proof we can show that if $x \preceq_v y$ for some preimputations x and y of v , then $(y - x) \cdot z \geq 0$ for every $z \in X(\mathcal{G}(x, v))$, thus $y - x \in Y$, where Y is defined in Lemma 2.3.
- (2) If $x \in \mathcal{M}(v)$, then $\bar{\mathcal{D}}(x, v) = \{x\}$.
If $y \in \bar{\mathcal{D}}(x, v)$ satisfies $y \neq x$, then $y - x \in Y$ by (1). However, in view of Lemma 2.3, $Y \neq \{(0, \dots, 0)\}$ is impossible for $x \in \mathcal{M}(v)$.

Proof of Theorem 2.2: Let Y be defined as in Lemma 2.3 and put $\mathcal{G} = \mathcal{G}(x, v)$. Then the following conditions are equivalent by the just mentioned lemma.

- (1) $x \in \mathcal{M}(v)$.
- (2) The linear programm P

$$\begin{aligned} & \max \sum_{z \in X(\mathcal{G})} y \cdot z \\ & \text{subject to } y(N) = 0, y \cdot z \geq 0 \text{ for } z \in X(\mathcal{G}) \end{aligned} \tag{2.3}$$

is feasible and its value is 0.

The dual program of P reads

$$\begin{aligned} & \min [(\beta_z)_{z \in X(\mathcal{G})}, \beta_N] \cdot (0, \dots, 0) \\ & \text{subject to } -\sum_{z \in X(\mathcal{G})} \beta_z z + \beta_N \mathbf{1}_N = \sum_{z \in X(\mathcal{G})} z, \beta_z \geq 0 \text{ for } z \in X(\mathcal{G}), \beta_N \in \mathbb{R} \end{aligned} \tag{2.4}$$

and, thus, $x \in \mathcal{M}(v)$ implies the existence of vectors β_z, β_N with the above properties. As $1 + \beta_z > 0$ we know that β_N must be positive in this case. We conclude that $\delta_z = (1 + \beta_z)/\beta_N$ are balancing coefficients.

It remains to show the converse direction of our assertion. If the configuration \mathcal{G} is feasible, take balancing coefficients $\delta_z > 0$ for $z \in X(\mathcal{G})$ and observe that $(\beta_z)_{z \in Z(\mathcal{G})}$ together with β_N defined by $\beta_z = \alpha\delta_z - 1$ and $\beta_N = \alpha$, where $\alpha = 1/\min\{\delta_z \mid z \in X(\mathcal{G})\}$, constitute a feasible and hence optimal solution (with value 0) of the dual programm of P. The duality theorem and the last lemma complete the proof of this direction. q.e.d.

Remark 2.5 A configuration $\mathcal{G} = (\mathcal{G}_i)_{i=1}^r$ is a **refinement** of the configuration $\mathcal{H} = (\mathcal{H}_i)_{i=1}^t$, if every component of \mathcal{H} is the union of consecutive components of \mathcal{G} , i.e.

$$\mathcal{H}_j = \bigcup_{i=i(j)}^{i(j+1)-1} \mathcal{G}_i \text{ for } j = 1, \dots, t \text{ such that } 1 = i(1) < \dots < i(t) < r + 1 = i(t + 1).$$

We will show that a configuration \mathcal{H} is feasible, if and only if it possesses a feasible refinement \mathcal{G} . Indeed, every configuration is a refinement of itself. For the converse implication, let \mathcal{G} be feasible. With the help of a recursive argument, it is sufficient to show this assertion for $r = t + 1$, i.e., if $\mathcal{H}_{\bar{j}} = \mathcal{G}_{\bar{j}} \cup \mathcal{G}_{\bar{j}+1}$, $\mathcal{H}_j = \mathcal{G}_{j+1}$ for $j > \bar{j}$, and $\mathcal{H}_j = \mathcal{G}_j$ for $j < \bar{j}$. In this case we have

$$(1) X(\mathcal{G}) \subseteq X(\mathcal{H}).$$

(2) $z \in X(\mathcal{H})$ with $z = \sum_{j=1}^k \sum_{S \in \mathcal{H}_j} 1_S + \sum_{S \in \mathcal{T}} 1_S$ for some $\mathcal{T} \subseteq \mathcal{H}_{k+1}$ implies $z \in X(\mathcal{G})$ for $0 \leq k < \bar{j} - 1$ or $r - 1 > k \geq \bar{j}$. The case $k = \bar{j} - 1$ can be treated as follows. Let

$$\bar{z} = \sum_{\mathcal{T} \subseteq \mathcal{H}_{\bar{j}}} \left(\sum_{j=1}^{\bar{j}-1} \sum_{S \in \mathcal{H}_j} 1_S + \sum_{S \in \mathcal{T}} 1_S \right)$$

and observe that

$$\begin{aligned} \bar{z} &= 2^{|\mathcal{H}_{\bar{j}}|} \cdot \sum_{j=1}^{\bar{j}-1} \sum_{S \in \mathcal{H}_j} 1_S + 2^{|\mathcal{H}_{\bar{j}}|-1} \cdot \sum_{S \in \mathcal{H}_{\bar{j}}} 1_S \\ &= 2^{|\mathcal{H}_{\bar{j}}|-1} \cdot \left(\sum_{j=1}^{\bar{j}} \sum_{S \in \mathcal{H}_j} 1_S + \sum_{j=1}^{\bar{j}-1} \sum_{S \in \mathcal{H}_j} 1_S \right) \\ &= 2^{|\mathcal{H}_{\bar{j}}|-1} \cdot \left(\sum_{j=1}^{\bar{j}+1} \sum_{S \in \mathcal{G}_j} 1_S + \sum_{j=1}^{\bar{j}-1} \sum_{S \in \mathcal{G}_j} 1_S \right), \end{aligned}$$

which shows that the sum of vectors in $X(\mathcal{H})$ which may not be in $X(\mathcal{G})$ can be expressed as a linear combination of elements of $X(\mathcal{G})$, i.e.

$$\bar{z} = \sum_{z \in X(\mathcal{G})} \beta_z \cdot z$$

for some $\beta_z \in \mathbb{R}$.

Let $\alpha_z > 0$ for $z \in X(\mathcal{G})$ be balancing coefficients for $X(\mathcal{G})$, i.e.

$$\sum_{z \in X(\mathcal{G})} \alpha_z \cdot z = 1_N,$$

and $\epsilon > 0$ be chosen such that $\alpha_z - \epsilon\beta_z > 0$ for $z \in X(\mathcal{G})$. Then the equation

$$1_N = \sum_{z \in X(\mathcal{G})} \alpha_z \cdot z = \sum_{z \in X(\mathcal{G})} (\alpha_z - \epsilon\beta_z) \cdot z + \epsilon\bar{z}$$

implies balancedness of $X(\mathcal{H})$.

Theorem 2.6 *The maximal satisfaction solution $\mathcal{M}(v)$ is a finite union of polytopes for every game (N, v) .*

Proof: For every feasible configuration $\mathcal{G} = (\mathcal{G}_i)_{i=1}^r$ define the set

$$\mathcal{M}_{\mathcal{G}} = \{x \in X(v) \mid f(S, x, v) \leq f(T, x, v) \text{ for } S \in \mathcal{G}_i, T \in \mathcal{G}_j \text{ and } 1 \leq i \leq j \leq r\},$$

which clearly is a polytope. On the other hand

$$\mathcal{M}_{\mathcal{G}} = \{x \in X(v) \mid \mathcal{G} \text{ is a refinement of } \mathcal{G}(x, v)\},$$

which by Remark 2.5 and Theorem 2.2 is a subset of $\mathcal{M}(v)$. Conversely, the just mentioned theorem implies that $\mathcal{G}(x, v)$ is feasible for $x \in \mathcal{M}(v)$. The number of (feasible) configurations is finite, thus the proof is finished. q.e.d.

We would like to apply these characterizing results to show that the maximal satisfaction solution satisfies reasonableness. First of all we show that the solution satisfies the strong nullplayer property (for single valued solution concepts also known as ‘nullplayer out property’ (see Derks and Haller (1995))) in the sense of the following

Definition 2.7 *A solution concept σ on a set Γ of games satisfies the **strong nullplayer property (SNPP)**, if for every game $(N, v) \in \Gamma$ and every nullplayer $i \in N$ of v the following condition is satisfied: If $(N \setminus \{i\}, w) \in \Gamma$ is the subgame of v which arises from v by deleting i , then $\sigma(v)$ arises from $\sigma(w)$ by adding a zero component for player i to every element of $\sigma(w)$, i.e.*

$$\sigma(v) = \{x \in \mathbb{R}^N \mid x_i = 0 \text{ and } x_{N \setminus \{i\}} \in \sigma(w)\}.$$

Note that SNPP implies NPP. Moreover, it should be remarked that many solution concepts (e.g. the Shapley value, Core, and the nucleoli) satisfy even the stronger property.

Remark 2.8 *Let $x \in \mathcal{M}(v)$. We can get as a corollary of Theorem 2.2 that $X(\mathcal{G}(x, v))$ is **separating**, that is, for all $i, j \in N$, $i \neq j$, there exist $a = a(i, j)$ and $b = b(i, j)$ in $X(\mathcal{G}(x, v))$ such that $a_i > a_j$ and $b_i < b_j$.*

Theorem 2.9 *The maximal satisfaction solution \mathcal{M} satisfies SNPP.*

Proof: For one-person games the solution satisfies NPP because of PO. Let (N, v) be a game, i be a nullplayer of v , and $x \in X(v)$. In order to show that $z_i = 0$ for $z \in \mathcal{M}(v)$ two cases are distinguished.

- (1) $x_i < 0$: The smallest satisfaction is only attained by coalitions $S \subseteq N$ which contain player i . Moreover, by PO and the fact $f(\{i\}, x, v) < 0$ such coalitions cannot coincide with the grand coalition N . Take any coalition S of minimal satisfaction and $j \in N \setminus S$. Using the above observation and the fact that $f(T, x, v) < f(T \setminus \{i\}, x, v)$ for all coalitions $T \subseteq N$ with $i \in T$ it is clear that $z_i \geq z_j$ for every $z \in X(\mathcal{G}(x, v))$. Moreover, the inequality is strict for at least one z . Therefore $x \notin \mathcal{M}(x, v)$ by Remark 2.8.
- (2) The case $x_i > 0$ can be treated analogously. Indeed, a coalition S which attains minimal satisfaction does neither contain i nor coincides with the empty set, because $f(N \setminus \{i\}, x, v) < 0$. Moreover, $f(T \cup \{i\}, x, v) > f(T, x, v)$ for $T \subseteq N \setminus \{i\}$. Therefore $z_i \leq z_j$ for $z \in X(\mathcal{G}(x, v))$ and $j \in S$. Consequently $x \notin \mathcal{M}(v)$ by Remark 2.8.

It remains to show that $\mathcal{M}(v) = \{x \in \mathbb{R}^N \mid x_i = 0 \text{ and } x_S \in \mathcal{M}(w)\}$, where $(N \setminus \{i\}, w)$ is the subgame of v .

- (1) (\subseteq) This inclusion is trivial for $|N| = 2$, thus we assume that N possesses at least three members. Let $x \in \mathcal{M}(v)$, thus $x_i = 0$ by NPP, and define $\tilde{x} = x_{N \setminus \{i\}}$. Take $\tilde{y} \in \mathbb{R}^{N \setminus \{i\}}$ which satisfies $\tilde{y}(N \setminus \{i\}) = 0$ and $\tilde{y} \cdot z \geq 0$ for $z \in X(\mathcal{G}(\tilde{x}, w))$. With $y = (\tilde{y}, 0) \in \mathbb{R}^N$ we come with $y(N) = 0$ and $y \cdot z \geq 0$ for $z \in X(\mathcal{G}(x, v))$. Indeed, if

$$z = \sum_{j=1}^k \sum_{S \in \mathcal{G}_j(x, v)} 1_S + \sum_{S \in \mathcal{T}} 1_S \quad (2.5)$$

for some $\mathcal{T} \subseteq \mathcal{G}_{k+1}(x, v)$, then

$$z_{N \setminus \{i\}} = 2 \sum_{j=1}^k \sum_{S \in \mathcal{G}_j(\tilde{x}, w)} 1_S + \sum_{S \in \mathcal{T}} 1_{S \cap N \setminus \{i\}}. \quad (2.6)$$

(Note that 1_S in equation (2.5) is considered to be a vector of \mathbb{R}^N , whereas in the second equation (2.6) it is considered to be in $\mathbb{R}^{N \setminus \{i\}}$.) With $\tilde{\mathcal{T}} = \{S \cap N \setminus \{i\} \mid S \in \mathcal{T}\}$, $\mathcal{T}_0 = \{S \in \tilde{\mathcal{T}} \mid S \in \mathcal{T} \ni S \cup \{i\}\}$, and $\mathcal{T}_1 = \tilde{\mathcal{T}} \setminus \mathcal{T}_0$ we have $\tilde{\mathcal{T}}, \mathcal{T}_0, \mathcal{T}_1 \subseteq \mathcal{G}_{k+1}(\tilde{x}, w)$ and we obtain

$$\begin{aligned} z_{N \setminus \{i\}} &= 2 \left(\sum_{j=1}^k \sum_{S \in \mathcal{G}_j(\tilde{x}, w)} 1_S + \sum_{S \in \mathcal{T}_0} 1_S \right) + \sum_{S \in \mathcal{T}_1} 1_S \\ &= \left(\sum_{j=1}^k \sum_{S \in \mathcal{G}_j(\tilde{x}, w)} 1_S + \sum_{S \in \mathcal{T}_0} 1_S \right) + \left(\sum_{j=1}^k \sum_{S \in \mathcal{G}_j(\tilde{x}, w)} 1_S + \sum_{S \in \mathcal{T}_0 \cup \mathcal{T}_1} 1_S \right) \\ &= \tilde{z}^0 + \tilde{z}^1 \end{aligned}$$

for some $\tilde{z}^0, \tilde{z}^1 \in X(\mathcal{G}(\tilde{x}, w))$. By satisfaction maximality $\tilde{y} \cdot \tilde{z}^0 \geq 0 \leq \tilde{y} \cdot \tilde{z}^1$, thus $y \cdot z \geq 0$ and Lemma 2.3 implies this inclusion.

- (2) (\supseteq) Let $\tilde{x} \in \mathcal{M}(w)$ and define $x = (\tilde{x}, 0) \in X(v)$. If there is $y \in X(v)$ with $y \succ_v x$, then $y \in \mathcal{M}(v)$ can be assumed by Corollary 1.4. Therefore $y_i = 0$ is true. For

$\tilde{z} \in X(\mathcal{G}(\tilde{x}, w))$, let us say

$$\tilde{z} = \sum_{j=1}^k \sum_{S \in \mathcal{G}_j(\tilde{x}, w)} 1_S + \sum_{S \in \mathcal{T}} 1_S$$

for some $\mathcal{T} \subseteq \mathcal{G}_{k+1}(\tilde{x}, w)$, define $z \in \mathbb{R}^N$ by

$$z_{N \setminus \{i\}} = 2 \cdot \tilde{z}, \quad z_i = \sum_{j=1}^k |\mathcal{G}_j(\tilde{x}, w)| + |\mathcal{T}|$$

and observe that $z \in X(\mathcal{G}(x, v))$ holds true. This shows that $(y_{N \setminus \{i\}} - \tilde{x}) \cdot \tilde{z} \geq 0$ is valid. Clearly, $y_{N \setminus \{i\}} - \tilde{x} \neq 0$ and, thus, Lemma 2.3 finishes the proof of this inclusion. q.e.d.

Theorem 2.10 *The maximal satisfaction solution is reasonable.*

Proof: Assume, on the contrary, \mathcal{M} does not satisfy REAS on some set Γ of games. Let $(N, v) \in \Gamma$ be a game and $x \in \mathcal{M}(v)$, such that there exists $i \in N$ with

$$d_i = \min\{v(S \cup \{i\}) - v(S) \mid S \subseteq N \setminus \{i\}\} > x_i \text{ or}$$

$$D_i = \max\{v(S \cup \{i\}) - v(S) \mid S \subseteq N \setminus \{i\}\} < x_i.$$

- (1) $x_i < d_i$: By COV we can assume that $d_i = 0$ holds true. Let $j \notin N$ and define $(N \cup \{j\}, u)$ to be the game which arises from v by adding one nullplayer j . By the SNPP $y = (x, 0) \in \mathcal{M}(u)$, but $y_i < d_i = 0 = y_j$ which contradicts DES.
- (2) The case $x_i > D_i$ can be treated analogously by interchanging the roles of $d_i, <$ and $D_i, >$. q.e.d.

Theorem 2.11 *For every game (N, v) the maximal satisfaction solution $\mathcal{M}(v)$ is contractible.*

Proof: The mapping $\mathcal{M}(v) \rightarrow \mathbb{R}^{2^n}$ defined by $x \mapsto L((f(S, x, v))_{S \subseteq N})$ is continuous and, by Remark 2.4 (2), injective. With $C = \{L((f(S, x, v))_{S \subseteq N}) \mid x \in \mathcal{M}(v)\}$ we conclude that

$$h : \mathcal{M}(v) \rightarrow C \text{ defined by } h(x) = L((f(S, x, v))_{S \subseteq N})$$

is a homeomorphism (because $\mathcal{M}(v)$ is compact). Let

$$D = \{z \in \mathbb{R}^{2^n} \mid \text{there is a } c \in C \text{ such that } c \geq z\}.$$

Then D is closed and convex (because the component functions h_k are concave) and C is the set of Pareto optimal points of D . Theorem 4.6 of Peleg (1972) directly implies that C is contractible. Therefore $\mathcal{M}(v)$ is contractible, because h is a homeomorphism. q.e.d.

Theorem 2.12 $\mathcal{M}(v)$ is a continuous function of v .

Proof:

- (1) **Lower hemicontinuity:** Let $(v_k)_{k \in \mathbb{N}}$ be a sequence of games on N with $\lim_{k \rightarrow \infty} v_k = v$ and let $x \in \mathcal{M}(v)$. Choose $x^k \in X^*(v_k)$, $k \in \mathbb{N}$, such that $\lim_{k \rightarrow \infty} x^k = x$. For each k there exists $y^k \in \mathcal{M}(v_k)$ such that $y^k \succeq_{v_k} x^k$. The sequence $(y^k)_{k \in \mathbb{N}}$ is bounded by Theorem 2.10. Let $(y^{k_j})_{j \in \mathbb{N}}$ be a convergent subsequence of $(y^k)_{k \in \mathbb{N}}$, and let $y = \lim_{j \rightarrow \infty} y^{k_j}$. Then $y \in X^*(v)$ and $y \succeq_v x$ (because

$$\begin{aligned} L_t((f(S, y, v))_{S \subseteq N}) &= \lim_{j \rightarrow \infty} L_t((f(S, y^{k_j}, v_{k_j}))_{S \subseteq N}) \geq \\ \lim_{j \rightarrow \infty} L_t((f(S, x^{k_j}, v_{k_j}))_{S \subseteq N}) &= L_t((f(S, x, v))_{S \subseteq N}), \quad t = 1, \dots, 2^n. \end{aligned}$$

Thus, by Remark 2.4, $y = x$.

- (2) **Upper hemicontinuity:** Let $\lim_{k \rightarrow \infty} v_k = v$, $x^k \in \mathcal{M}(v_k)$, $k \in \mathbb{N}$, and $\lim_{k \rightarrow \infty} x^k = x$. Without loss of generality we can assume that $\mathcal{G}(x^k, v_k) = \mathcal{G}$ for every $k \in \mathbb{N}$. By Theorem 2.2 \mathcal{G} is feasible and, clearly, it is a refinement of $\mathcal{G}(x, v)$. By Remark 2.5 $\mathcal{G}(x, v)$ is feasible. Therefore by Theorem 2.2 $x \in \mathcal{M}(v)$. q.e.d.

3 The Nucleolus as the Unique Minimizer of a Weighted Gini Index

In this section we fix a finite nonvoid set N and denote the set of games with player set N by $\Gamma = \{(N, v) \mid v \text{ is a game}\}$.

Definition 3.1 A function $U : \mathbb{R}^N \times \Gamma \rightarrow \mathbb{R}$ is a **collective satisfaction function reducing inequality**, if there exists a collective utility function $W : \mathbb{R}^{2^N} \rightarrow \mathbb{R}$ reducing inequality such that

$$U(x, v) = W((f(S, x, v))_{S \subseteq N})$$

holds true for $x \in \mathbb{R}^N$ and $v \in \Gamma$.

We are going to show that there is a collective satisfaction function U reducing inequality such that the nucleolus (pre- or antinucleolus respectively) is the unique maximizer of $U(\cdot, v)$ restricted to the set of feasible payoffs $X^*(v)$ of v . Moreover, it will be shown that U can be chosen in such a way that the induced inequality index is a weighted Gini index.

Recall (see Kolm (1966) and Atkinson (1970)) that a collective utility function $W : \mathbb{R}^N \rightarrow \mathbb{R}$ reducing inequality **induces an inequality index** $G = G^W : \mathbb{R}_{\geq 0}^N \setminus \{0\} \rightarrow \mathbb{R}$, defined by

$$G(x) = 1 - (n \cdot \alpha(x))/x(N), \tag{3.1}$$

where $\alpha(x) \in \mathbb{R}_{>0}$ is the unique real number satisfying

$$W(\alpha(x) \cdot 1_N) = W(x).$$

(Recall that W is assumed to be continuous.) An inequality index G satisfies $G(x) < G(y)$ for $x, y \in \mathbb{R}_{\geq 0}^N \setminus \{0\}$ with $x(N) = y(N)$ whenever x Lorenz dominates y .

In case

$$W(x) = \sum_{i=1}^n [(2(n-i) + 1)/n^2] \cdot x_i^\bullet, \quad (3.2)$$

i.e.

$$G(x) = 1 - (n/x(N)) \sum_{i=1}^n [(2(n-i) + 1)/n^2] \cdot x_i^\bullet, \quad (3.3)$$

the induced inequality index is the **Gini index**. It takes the surface between the ‘straight line’, i.e. the Lorenz curve of the ‘equal treatment vector’ $(x(N), \dots, x(N))/n$, and the Lorenz curve of x as a measure of inequality of x . Indeed, note that (3.3) can be rewritten as

$$G(x) = \sum_{i=1}^n ((i \cdot x(N))/n - L_i(x)) / [(n \cdot x(N))/2]. \quad (3.4)$$

For this notation Moulin (1988) is referred to.

Every strictly decreasing finite sequence $p = (p_1, \dots, p_n)$ of positive real numbers with total weight 1, i.e.

$$p_1 > \dots > p_n > 0, p(N) = 1,$$

(p is called **descending probability on** $\{1, \dots, n\}$) defines a collective utility function $W_p : \mathbb{R}^N \rightarrow \mathbb{R}$ analogously to (3.2) by

$$W_p(x) = \sum_{i=1}^n p_i x_i^\bullet = p_n L_n(x) + \sum_{i=1}^{n-1} (p_i - p_{i+1}) L_i(x). \quad (3.5)$$

By the nonincreasingness and positivity of p the collective utility function W_p reduces inequality. The induced inequality index G_p is a **weighted Gini index** (cf. Sudhölter (1996b)). The difference between the ‘classical’ Gini index and a weighted Gini index can be seen by looking at the formula

$$G_p(x) = (n/x(N)) \cdot \sum_{i=1}^{n-1} (p_i - p_{i+1}) (i \cdot x(N)/n - L_i(x)). \quad (3.6)$$

Therefore G_p puts weight $p_i - p_{i+1}$ to i . The Gini index is proportional to the surface between the straight line and the Lorenz curve (i.e. the Gini index G is a special weighted index such that consecutive weights are equidistant), whereas G_p ‘distorts’ the axis before measuring the surface. Figure 3.1 sketches the Lorenz curves and the ‘distorted’ Lorenz curves of $x = (2, 2, 14)$ and $y = (0, 9, 9)$, where $p = (6, 2, 1)/9$. In this case G_p puts larger weights to ‘poorer people’. Indeed, the horizontal distances between consecutive players in the left part of the figure (which sketches the ‘classical’ Gini index) are equal, whereas the horizontal distance between i and $i + 1$ in the right part of the figure (which sketches G_p) is proportional to $p_i - p_{i+1}$. In this example $G(x) > G(y)$ and $G_p(x) < G_p(y)$.

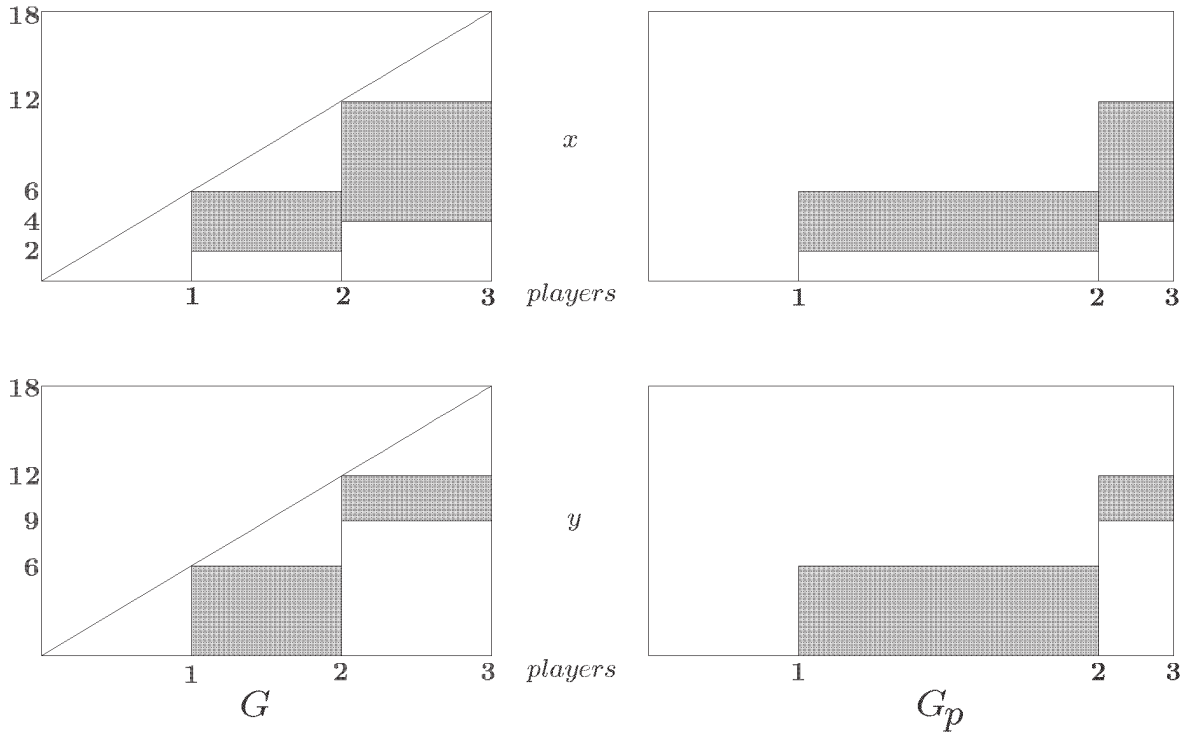

Figure 3.1: Gini index versus G_p

Unfortunately the definition of inequality indices cannot directly be generalized to utility profiles which possess negative entries. In our situation we would like to have the notion of inequality indices for satisfaction vectors. As the interest is mainly restricted to preimputations the normalization factor ‘ $n/x(N)$ ’ can be dropped in formula 3.6. Therefore we will frequently replace equation 3.6 by

$$G_p(x, v) = \sum_{i=1}^{2^n-1} (p_i - p_{i+1}) \cdot (i \cdot \bar{f}(x, v) - L_i((f(S, x, v))_{S \subseteq N})) \quad (3.7)$$

from now on. Here $\bar{f}(x, v) = (1/2^n) \cdot \sum_{S \subseteq N} f(S, x, v)$.

Moreover, for every descending probability $p \in \mathbb{R}^{2^n}$ define $U_p : \mathbb{R}^N \times \Gamma \rightarrow \mathbb{R}$ by $U_p(x, v) = W_p((f(S, x, v))_{S \subseteq N})$, i.e.

$$U_p(x, v) = \sum_{i=1}^{2^n} p_i \cdot F_i(x, v), \quad (3.8)$$

where

$$((f(S, x, v))_{S \subseteq N})_i^\bullet = F_i(x, v) = \min\{\max\{f(S, x, v) \mid S \in \mathcal{S}\} \mid \mathcal{S} \subseteq 2^N \text{ and } |\mathcal{S}| = i\}.$$

Every $c > 1$ determines a descending probability $p = p^c \in \mathbb{R}^{2^n}$ by

$$p_i = [(c - 1)/(c^{2^n} - 1)] \cdot c^{2^n - i} \text{ for } i = 1, \dots, 2^n.$$

Theorem 3.2 *There is a $c_0 \geq 1$ such that for every $c > c_0$ the prenucleolus is the unique maximizer of U_{p^c} , i.e.*

$$\operatorname{argmax}\{U_{p^c}(x, v) \mid x \in X^*(v)\} = \{\nu(v)\} \quad (3.9)$$

for every $v \in \Gamma$.

This theorem is a direct consequence of Theorem 4.1 of Kohlberg (1972). Indeed, note that Kohlberg's assumption of zero-normalized games is not needed in his proofs, and can, thus, be dropped. Moreover, it should be remarked that in view of Lemma 1.5 and Theorem 2.10 equation 3.9 can be replaced by

$$\operatorname{argmax}\{U_{p^c}(x, v) \mid x \in X\} = \{\nu(v)\}, \quad (3.10)$$

for every set $X \subseteq X(v)$ satisfying $X \supseteq \{x \in X(v) \mid x \text{ is reasonable}\}$. By COV of \mathcal{M} and ν we can assume without loss of generality that $v(N) = 0$ and that the marginal contributions of every player are bounded by -1 from below and $+1$ from above, i.e.

$$-1 \leq v(S \cup \{i\}) - v(S) \leq 1 \text{ for } S \subseteq N \setminus \{i\} \text{ and } i \in N$$

is satisfied. Therefore $X = \{x \in \mathbb{R}^N \mid x(N) = 0 \text{ and } -1 \leq x_i \leq 1 \text{ for } i \in N\}$ possesses the desired properties. As X is a polytope Kohlberg's result applies.

Remark 3.3 *Let $(N, v) \in \Gamma$ and $x \in X(v)$. Denote $h(x) = L((f(S, x, v))_{S \subseteq N})$. Then*

$$h_k(x) = \min\left\{\sum_{S \in \mathcal{S}} f(S, x, v) \mid \mathcal{S} \subseteq 2^N \text{ and } |\mathcal{S}| = k\right\}$$

for $k = 1, \dots, 2^n$. Hence $h_k(\cdot)$ is a polyhedral concave function for each k . As in the proof of Theorem 2.11 let

$$D = \{z \in \mathbb{R}^{2^n} \mid \text{there is } x \in \mathcal{M}(v) \text{ such that } h(x) \geq z\}.$$

Then D is a polyhedral convex set whose set of Pareto optimal points is $C = h(\mathcal{M}(v))$. It is easily verified that the (finite) set of extreme points of D is contained in C . A point $z \in C$ is exposed, if it is extreme (because D is polyhedral). Thus, a point $x \in \mathcal{M}(v)$ is the unique maximizer of a collective satisfaction function of the form

$$U(y) = \sum_{k=1}^{2^n} p_k L_k((f(S, y, v))_{S \subseteq N}), \quad y \in X(v),$$

where $p_k > 0$, $k = 1, \dots, 2^n$, iff $z = h(x)$ is an extreme point of D . Thus $h(\nu(v))$ is an extreme point of D (this can also be verified directly from the definitions of ν and D ; notice that $h(\nu(v))$ is the lexicographic maximum of D).

In order to obtain a similar result for the antinucleolus define for every descending probability $p \in \mathbb{R}^{2^n}$ the dual vector $p^* \in \mathbb{R}^{2^n}$ by

$$p_i^* = (1 - p_{2^n+1-i}) / (2^n - 1) \text{ for } i = 1, \dots, 2^n$$

and note that p^* is a descending probability in \mathbb{R}^{2^n} .

Theorem 3.4 *There is a $c_0 \geq 1$ such that for every $c > c_0$ the antinucleolus is the unique maximizer of $U_{p^{c^*}}$, i. e.*

$$\operatorname{argmax}\{U_{p^{c^*}}(x, v) \mid x \in X^*(v)\} = \{\nu^*(v)\} \quad (3.11)$$

for every $v \in \Gamma$.

Proof: By Lemma 1.5 equation 3.11 is equivalent to

$$\operatorname{argmax}\{U_{p^{c^*}}(x, v) \mid x \in X(v)\} = \{\nu^*(v)\} \quad (3.12)$$

and, hence, to

$$\operatorname{argmax}\{-(2^n - 1) \sum_{S \subseteq N} f(S, x, v) + (2^n - 1)U_{p^{c^*}}(x, v) \mid x \in X(v)\} = \{\nu^*(v)\}. \quad (3.13)$$

Let $x \in X(v)$. With the help of equation 3.5, $F_i(x, v)$ as defined in formula 3.8, and $q = p^{c^*}$ we come up with

$$\begin{aligned} & -(2^n - 1) \sum_{S \subseteq N} f(S, x, v) + (2^n - 1)U_q(x, v) \\ = & -(2^n - 1)L_{2^n}(F(x, v)) + (2^n - 1)[q_{2^n}L_{2^n}(F(x, v)) \\ & + \sum_{i=1}^{2^n-1}(q_i - q_{i+1})L_i(F(x, v))] \\ = & (2^n - 1)L_{2^n}(F(x, v^*)) + (2^n - 1)[-q_{2^n}L_{2^n}(F(x, v^*)) \\ & + \sum_{i=1}^{2^n-1}(q_i - q_{i+1})(L_{2^n-i}(F(x, v^*)) - L_{2^n}(F(x, v^*)))] \\ = & p_{2^n}^c L_{2^n}(F(x, v^*)) + \sum_{i=1}^{2^n-1} p_i^c L_i(F(x, v^*)) \\ = & U_{p^c}(x, v^*). \end{aligned}$$

The second equality is guaranteed by $L_i(F(x, v)) = L_{2^n-i}(F(x, v^*)) - L_{2^n}(F(x, v^*))$ for $i = 0, \dots, 2^n$ ($L_0(\cdot) = 0$ by convention). Therefore equation 3.13 is equivalent to

$$\operatorname{argmax}\{U_{p^c}(x, v^*) \mid x \in X(v^*)\} = \{\nu^*(v)\} \quad (3.14)$$

which is valid by Theorem 3.2 for c large enough.

q.e.d.

Note that

$$p_i^c - p_{i+1}^c \text{ is proportional to } c^{2^n-i-1}$$

and

$$p_i^{c^*} - p_{i+1}^{c^*} \text{ is proportional to } c^{i-1}$$

for $i = 1, \dots, 2^n-1$. Therefore Theorem 3.2 and 3.4 can be reformulated in terms of weighted Gini indices. Let $G_c^\nu, G_c^{\nu^*} : \mathbb{R}^N \times \Gamma \rightarrow \mathbb{R}$ be defined by

$$G_c^\nu(x, v) = \sum_{i=1}^{2^n-1} c^{2^n-i-1} (i \cdot L_{2^n}((f(S, x, v))_{S \subseteq N}) / 2^n - L_i((f(S, x, v))_{S \subseteq N}))$$

and

$$G_c^{\nu^*}(x, v) = \sum_{i=1}^{2^n-1} c^{i-1} (i \cdot L_{2^n}((f(S, x, v))_{S \subseteq N}) / 2^n - L_i((f(S, x, v))_{S \subseteq N})).$$

Corollary 3.5 *There exists $c_0 \geq 1$ such that for every $c > c_0$ and every $v \in \Gamma$*

- (1) $\operatorname{argmin} \{G_c^\nu(x, v) \mid x \in X(v)\} = \{\nu(v)\}$ and
- (2) $\operatorname{argmin} \{G_c^{\nu^*}(x, v) \mid x \in X(v)\} = \{\nu^*(v)\}$.

Intuitively, G^ν puts exponentially larger weights to larger aggregate excesses (i.e. smaller satisfactions play a ‘dominant role’), whereas for G^{ν^*} the opposite is true. Hence a possible minimizer has to take care of relatively large lowest satisfactions in the first case and of relatively small highest satisfactions in the second case.

A constant c_0 which guarantees these results may depend on the cardinality of the player set N . We are going to present one possible candidate. Recall that a subset $\mathcal{S} \subseteq 2^N$ is called **balanced**, if the set $\{1_S \mid S \in \mathcal{S}\}$ is balanced (see Section 2). It is well-known that every balanced \mathcal{S} , which does not contain the empty coalition, is the union of its minimal balanced subcollections. The balancing coefficients for a **minimal** balanced collection of coalitions are uniquely determined. Moreover, all minimal balanced collections of a finite set can be generated recursively w.r.t. the number of players as shown by Peleg (1965). In view of this fact it is possible to compute $\beta(\mathcal{S}) = \max\{\delta_S/\delta_T \mid S, T \in \mathcal{S}\}$ for every minimal balanced set \mathcal{S} , where $(\delta_S)_{S \in \mathcal{S}}$ are the balancing coefficients of \mathcal{S} .

Note that $c(n) = \sum \beta(\mathcal{S})$, where the sum has to be taken over all minimal balanced collections \mathcal{S} of coalitions of N , is completely determined by the cardinality $n = |N|$.

Theorem 3.6 *For the real number c_0 which occurs in Theorems 3.2 and 3.4 any $c_0 \geq c(n)$ can be chosen.*

For a proof of this theorem the appendix is referred to.

4 The Modified Nucleolus as the Unique Minimizer of an Inequality Index

So far we have characterized two ‘classical’ single valued members of the maximal satisfaction solution, namely the pre- and the antinucleolus. Common to \mathcal{M} they satisfy AN, ETP, DES, COV, PO, SNPP, and REAS. Unfortunately none of these single valued solutions satisfies self duality. The modified nucleolus introduced by Sudhölter (1996a,1997) possesses all of the mentioned properties including SD. In what follows we briefly recall the definition and show that it is a member of the maximal satisfaction solution by directly proving that it maximizes a certain collective satisfaction function which reduces inequality.

For every game (N, v) the **modified nucleolus** $\Psi(v)$ is the set of preimputations of v which lexicographically minimize the nonincreasingly ordered vector of excess difference, i.e.

$$\Psi(v) = \{x \in X(v) \mid H^\bullet(x) \geq_{lex} H^\bullet(y) \text{ for } y \in X(v)\} \quad (4.1)$$

where $H(x) = (f(S, x, v) - f(T, x, v))_{S, T \subseteq N} \in \mathbb{R}^{2^N \times 2^N}$. The modified nucleolus satisfies SIVA. Let $\psi(v)$ be the unique element of $\Psi(v)$. Moreover, Ψ can be redefined by

$$\Psi(v) = \{x \in X^*(v) \mid \bar{H}^\bullet(x) \geq_{lex} \bar{H}^\bullet(y) \text{ for } y \in X^*(v)\} \quad (4.2)$$

where $\bar{H}(x) = (f(S, x, v) + f(T, x, v^*))_{S, T \subseteq N}$. The modified nucleolus satisfies the above mentioned properties. For detailed proofs Südhölder (1996a, 1997) is referred to.

For every descending probability $p \in \mathbb{R}^{n^2}$ define $\tilde{W}_p : \mathbb{R}^N \rightarrow \mathbb{R}$ by

$$\tilde{W}_p(x) = \sum_{i=1}^{n^2} p_i \cdot z_i^\bullet, \quad (4.3)$$

where $z(x) = z = (x_i - x_j + x(N))_{i, j \in N} \in \mathbb{R}^N \times \mathbb{R}^N$. Clearly \tilde{W}_p satisfies anonymity. The verification of unanimity is straightforward and left to the reader. Moreover, \tilde{W}_p reduces inequality as shown in the following

Lemma 4.1 *For every descending probability $p \in \mathbb{R}^{n^2}$ the arising collective utility function \tilde{W}_p reduces inequality.*

Proof: It is sufficient (see Moulin (1988)) to show that \tilde{W}_p satisfies the **Pigou-Dalton principle**:

$\tilde{W}_p(x) > \tilde{W}_p(y)$ holds true for and any two vectors $x, y \in \mathbb{R}^N$ with $x(N) = y(N)$, $x_k = y_k$ for $k \in N \setminus \{i, j\}$ and $|x_i - x_j| < |y_i - y_j|$, where $i, j \in N, i \neq j$ are arbitrary.

Without loss of generality $y_i > y_j$ can be assumed. Let ϵ be defined by $x_i = y_i - \epsilon$ (i.e. $x_j = y_j + \epsilon$ is automatically true). Moreover, by anonymity we can assume that $x_i \geq x_j$, thus $\epsilon > 0$. For $k, r \in N \setminus \{i, j\}$ we have

$$\begin{aligned} x_i - x_j &= y_i - y_j - 2\epsilon &\geq x_j - x_i &= y_j - y_i + 2\epsilon \\ x_i - x_k &= y_i - y_k - \epsilon &\geq x_j - x_k &= y_j - y_k + \epsilon \\ x_k - x_j &= y_k - y_j - \epsilon &\geq x_k - x_i &= y_k - y_i + \epsilon \\ x_k - x_r &= y_k - y_r. \end{aligned}$$

Therefore $z(x) \geq z(y)$, $z(x) \neq z(y)$ and, thus, the Pigou-Dalton principle is implied by decreasingness and positivity of p . q.e.d.

The induced inequality index coincides (up to normalization) with

$$\tilde{G}_p(x) = \sum_{i=1}^{n^2-1} (p_i - p_{i+1}) \cdot (i \cdot x(N) - L_i((x_k - x_r + x(N))_{k, r \in N})), \quad (4.4)$$

because equation 4.3 can be rewritten as

$$\tilde{W}_p(x) = p_{n^2} L_{n^2}((x_k - x_r + x(N))_{k, r \in N}) + \sum_{i=1}^{n^2-1} (p_i - p_{i+1}) L_i((x_k - x_r + x(N))_{k, r \in N}). \quad (4.5)$$

In this sense we could call \tilde{G}_p a **dually weighted Gini index**.

For $c > 1$ define $\tilde{p}^c \in \mathbb{R}^{2^{2n}}$ by

$$\tilde{p}_i^c = [(c-1)/(c^{2^{2n}} - 1)]c^{2^{2n}-i} \text{ for } i = 1, \dots, 2^{2n}$$

and observe that \tilde{p} is a descending probability on $\{1, \dots, 2^{2n}\}$. With $\tilde{U}_c : \mathbb{R}^N \times \Gamma \rightarrow \mathbb{R}$, defined by

$$\tilde{U}_c(x, v) = \tilde{W}_{\tilde{p}^c}((f(S, x, v))_{S \subseteq N})$$

we obtain the following result.

Theorem 4.2 *There is a $c_1 \geq 1$ such that for every $c > c_1$ the modified nucleolus is the unique maximizer of \tilde{U}_c , i.e.*

$$\operatorname{argmax}\{\tilde{U}_c(x, v) \mid x \in X^*(v)\} = \{\psi(v)\} \quad (4.6)$$

for every $v \in \Gamma$.

Proof: By Lemma 1.5 and Theorem 2.10 $X^*(v)$ can be replaced by every set X of preimputations such that $X \supseteq \{x \in X(v) \mid x \text{ is reasonable}\}$ is satisfied. As in Section 3 we can assume that v is chosen in such a way that $X = \{x \in \mathbb{R}^N \mid -1 \leq x_i \leq 1, i \in N, x(N) = 0\}$ possesses the desired properties. More precisely, equation 4.6 is equivalent to

$$\operatorname{argmax}\left\{\sum_{i=1}^{2^{2n}} c^{2^{2n}-i} G_i(x, v) \mid x \in X\right\} = \{\psi(v)\}, \quad (4.7)$$

where

$$G_i(x, v) = \min\{\max\{f(S, x, v) - f(T, x, v) \mid (S, T) \in \mathcal{S}\} \mid \mathcal{S} \subseteq 2^N \times 2^N \text{ and } |\mathcal{S}| = i\}$$

for $i = 1, \dots, 2^{2n}$. Take a disjoint copy N^* of N and define the **dual replication** $(N \cup N^*, \bar{v})$ of v by

$$\bar{v}(S \cup T^*) = v(S) + v^*(T) \text{ for } S, T \subseteq N.$$

Corollaries 1.6 and 2.6 of Sudhölter (1997) show that

$$\mathcal{N}(Z, \bar{v}) = \{x \in Z \mid x_N = \psi(v)\},$$

where $Z = \{x \in \mathbb{R}^{N \cup N^*} \mid x_N \in X \text{ and } x_i = x_i^* \text{ for } i \in N\}$. Kohlberg's (1972) result (Theorem 4.1) applied to (Z, \bar{v}) finishes the proof. q.e.d.

This theorem can be reformulated with the help of the dually weighted Gini index $G_c^\psi = \tilde{G}_{\tilde{p}^c}$.

Corollary 4.3 *There exists $c_1 > 1$ such that for every $c \geq c_1$ and every $v \in \Gamma$*

$$\operatorname{argmin}\{G_c^\psi(x, v) \mid x \in X(v)\} = \{\psi(v)\}.$$

Theorem 4.4 For the real number c_1 which occurs in Theorem 4.2 any $c_1 \geq 2 \cdot c(2n)$ can be chosen.

For a proof of this theorem the appendix is referred to.

Example 4.5 Let (N, v) be the 4-person weighted majority game, given by $N = \{1, 2, 3, 4\}$ and

$$v(S) = \begin{cases} 1 & , \text{ if } m(S) \geq 5 \\ 0 & , \text{ otherwise} \end{cases},$$

where $m = (3, 2, 1, 1)$. The nucleoli can be computed as:

$$\nu = \nu(v) = (1, 0, 0, 0) \quad \nu^* = \nu^*(v) = (1, 1, 0, 0)/2 \quad \psi = \psi(v) = m/7$$

The corresponding Lorenz curves of the satisfaction vectors (L^σ refers to the Lorenz curve of satisfactions w.r.t. σ) are sketched in Figure 4.1. Note that $L_i(\cdot)$ and $L_{i+1}(\cdot)$ are connected via a straight line in order to get a ‘curve’.

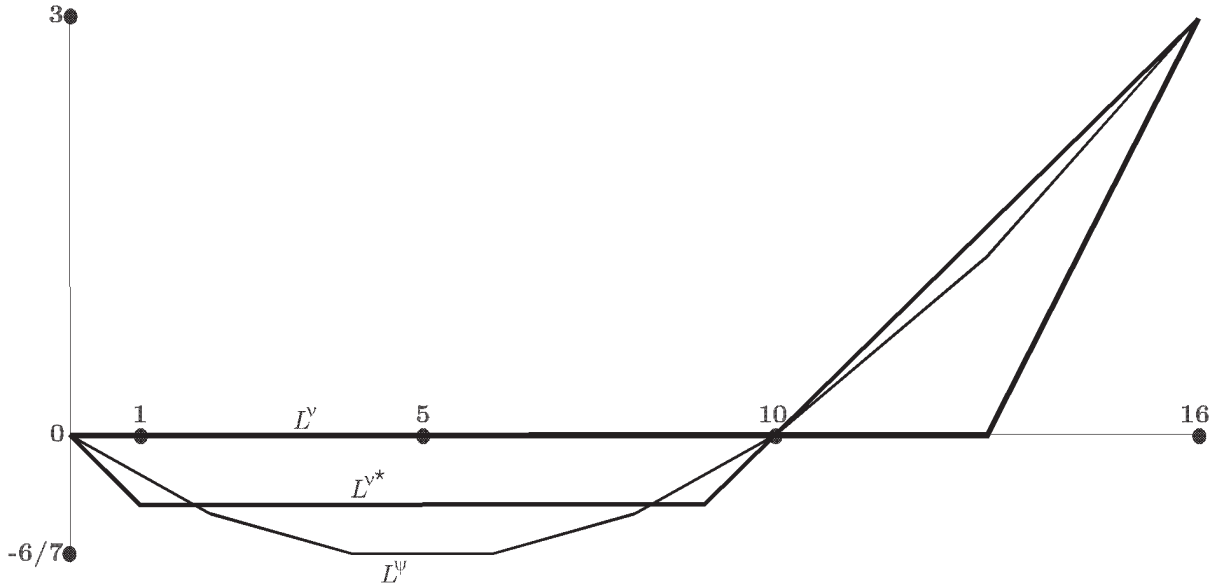

Figure 4.1: Lorenz curves of satisfactions

We apply Theorem 2.2 in order to show that the maximal satisfaction solution is the **convex hull (CH)** of the three nucleoli, i.e.

$$\mathcal{M} = \mathcal{M}(v) = CH \{ \nu, \nu^*, \psi \}$$

holds true (see Figure 4.2).

- (1) $\mathcal{M}(v) \supseteq CH \{ \nu, \nu^*, \psi \}$: Let $x \in CH \{ \nu, \nu^*, \psi \} = Y$. Then the minimal satisfaction at x is attained by $S^1 = \{1, 3, 4\}$, because the satisfaction of S^1 is minimal at every

extremal point of Y . Note that S^1 is the unique coalition of minimal satisfaction

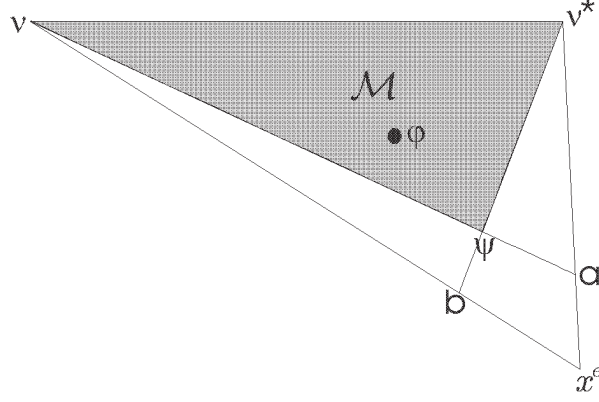

Figure 4.2: The Set $\mathcal{M}(v)$

at v^* . The coalition $S^2 = \{1, 2\}$ possesses minimal satisfaction at v , ψ and second lowest satisfaction at v^* , thus

$$z^1 = 1_{S^1} = (1, 0, 1, 1) \text{ and } z^2 = 1_{S^1} + 1_{S^2} = (2, 1, 1, 1)$$

are members of $X(\mathcal{G}(x, v))$.

The highest satisfaction at every extremal point of Y is attained by $S^3 = \{1, 3\}$ and $S^4 = \{1, 4\}$, thus

$$z^3 = \sum_{S^3 \neq S \subseteq N} 1_S = (2^{n-1} - 1, 2^{n-1}, 2^{n-1} - 1, 2^{n-1}) = (7, 8, 7, 8)$$

and

$$z^4 = \sum_{S^4 \neq S \subseteq N} 1_S = (7, 8, 8, 7)$$

are members of $X(\mathcal{G}(x, v))$. Let $A = \{z^1, z^2, z^3, z^4\}$. The proof that A spans \mathbb{R}^N is straightforward and skipped. The observation that

$$(1/17) \cdot (z^1 + z^2 + z^3 + z^4) = 1_N$$

is valid, implies that A is balanced. Every finite superset in the span of a balanced set is automatically balanced, hence $X(\mathcal{G}(x, v))$ is balanced, thus Theorem 2.2 implies $x \in \mathcal{M}(v)$.

- (2) $\mathcal{M}(v) \subseteq Y$: Let $x^e = (1, 1, 1, 1)/4$ denote the ‘equal treatment’ preimputation. By PO, DES, and ETP

$$\mathcal{M}(v) \subseteq CH \{v, v^*, x^e\}$$

is valid. For an arbitrary vector $x \in CH \{v, v^*, x^e\} \setminus Y$ two cases may occur.

- (a) $x_1 < x_2 + x_3$: (This means that x is a member of the convex hull of v^* , b , x^e but it is not on the line segment connecting v^* and b (see Figure 4.2).) The four coalitions R^i , $i = 1, \dots, 4$ satisfying $3 \notin S^i \ni 1$ can be characterized by the corresponding indicator vectors as

$$1_{R^1} = (1, 0, 0, 1), 1_{R^2} = (1, 0, 0, 0), 1_{R^3} = (1, 1, 0, 0), 1_{R^4} = (1, 1, 0, 1).$$

Conversely, let T^i , $i = 1, \dots, 4$ satisfy $1 \notin T^i \ni 3$, namely

$$1_{T^1} = (0, 1, 1, 1), 1_{T^2} = (0, 1, 1, 0), 1_{T^3} = (0, 0, 1, 1), 1_{T^4} = (0, 0, 1, 0).$$

The observation that $f(R^i, x, v) < f(T^i, x, v)$ holds true for $i = 1, \dots, 4$ directly implies $z_1 \geq z_3$ for every $z \in X(\mathcal{G}(x, v))$ and $z_1 > z_3$ for some $z \in X(\mathcal{G}(x, v))$. Therefore $x \notin \mathcal{M}(v)$ by Remark 2.8.

- (b) $x_1 > x_2 < 2x_3 = x_3 + x_4$: (This means that x is a member of the convex hull of v , a , x^e but it is not on the line segments connecting v and a or a and x^e respectively (see Figure 4.2).) This case can be treated analogously by first defining coalitions R^i , T^i by

$$1_{R^1} = (1, 1, 0, 1), 1_{R^2} = (0, 1, 0, 1), 1_{R^3} = (0, 1, 0, 0), 1_{R^4} = (1, 1, 0, 0),$$

$$1_{T^1} = (0, 0, 1, 0), 1_{T^2} = (1, 0, 1, 0), 1_{T^3} = (0, 0, 1, 1), 1_{T^4} = (1, 0, 1, 1),$$

and then observing $f(R^i, x, v) < f(T^i, x, v)$, thus $z_2 \geq z_3$ holds for every $z \in X(\mathcal{G}(x, v))$ and $z_2 > z_3$ for some $z \in X(\mathcal{G}(x, v))$.

In this case the Shapley value can be computed as $\varphi = \varphi(v) = (7, 3, 1, 1)/12$ and is, thus, a member of the maximal satisfaction solution.

5 Appendix

This section serves to prove Theorems 3.6 and 4.4. The following result is of technical nature and used in the sequel.

Lemma 5.1 Let $n, k \in \mathbb{N}$, $x, y \in \mathbb{R}^n$, and $\delta^r \in \mathbb{R}_{>0}^{t_r}$ for $r = 1, \dots, k$ such that

$$0 < t_1 < \dots < t_k = n; \tag{5.1}$$

$$x_{t_{r-1}+1} = \dots = x_{t_r} \quad \text{for } r = 1, \dots, k \text{ (where } t_0 = 0); \tag{5.2}$$

$$y_{t_{r-1}+1} \leq \dots \leq y_{t_r}$$

$$\sum_{i=1}^{t_r} \delta_i^r x_i = \sum_{i=1}^{t_r} \delta_i^r y_i \quad \text{for } r = 1, \dots, k. \tag{5.3}$$

If $c = \max\{\delta_i^r / \delta_j^r \mid r = 1, \dots, k; i, j = 1, \dots, t_r\}$ and $\beta \in \mathbb{R}^n$ satisfies $\beta_n \geq 0$ and $\beta_i > c \cdot \beta_{i+1}$ for $i = 1, \dots, n-1$, then

$$\sum_{i=1}^n \beta_i x_i \geq \sum_{i=1}^n \beta_i y_i. \tag{5.4}$$

Moreover,

$$\sum_{i=1}^n \beta_i x_i = \sum_{i=1}^n \beta_i y_i, \text{ iff } x = y. \tag{5.5}$$

Proof (by induction on k):

- (1) $k=1$. Let $\delta = \delta^1$ and $d = x_1$, i.e. $x = (d, \dots, d)$. If $n = 1$, both assertions ((5.4) and (5.5)) are obviously valid. Assume (5.4) and (5.5) are proved for $n < m$ for some $m > 1$. If $n = m$, then $y_1 \leq d$ is true by (5.2) and (5.3). If $y_1 = d$, then again by (5.2) and (5.3) $x = y$. Therefore we can assume $y_1 < d$, let us say $y_1 = d - \epsilon$ for some $\epsilon > 0$. We come up with

$$\begin{aligned} \sum_{i=2}^n \delta_i y_i &= d \cdot \sum_{i=1}^n \delta_i - \delta_1 y_1 \\ &= d \cdot \sum_{i=1}^n \delta_i - \delta_1 (d - \epsilon) \\ &= \left(d + (\delta_1 \epsilon / \sum_{i=2}^n \delta_i) \right) \sum_{i=2}^n \delta_i, \end{aligned}$$

thus the inductive hypothesis guarantees

$$\sum_{i=2}^n \beta_i y_i \leq \left(d + (\delta_1 \epsilon / \sum_{i=2}^n \delta_i) \right) \sum_{i=2}^n \beta_i. \quad (5.6)$$

The observation

$$\begin{aligned} \sum_{i=1}^n \beta_i y_i &\leq \beta_1 (d - \epsilon) + \left(d + (\delta_1 \epsilon / \sum_{i=2}^n \delta_i) \right) \cdot \sum_{i=2}^n \beta_i \quad (\text{by (5.6)}) \\ &= d \sum_{i=1}^n \beta_i + \epsilon \cdot \left((\delta_1 / \sum_{i=2}^n \delta_i) \sum_{i=2}^n \beta_i - \beta_1 \right) \end{aligned}$$

shows that the proof is finished in this case as soon as

$$\delta_1 \sum_{i=2}^n \beta_i < \sum_{i=2}^n \delta_i \beta_1 \quad (5.7)$$

is shown. By the properties of β we have $\beta_1 > \beta_2 \cdot \delta_1 / \delta_j$ for $j = 2, \dots, n$, thus

$$\begin{aligned} \sum_{i=2}^n \delta_i \beta_1 &\geq (n-1) \beta_1 \min_{i=2, \dots, n} \delta_i \\ &> (n-1) \beta_2 \delta_1 \geq \delta_1 \sum_{i=2}^n \beta_i, \end{aligned}$$

which shows (5.7).

- (2) By (1), assume that (5.4) and (5.5) are verified for $k < m$ and some $m > 1$. If $k = m$, then define $\delta = \delta^k$, $p = t_{k-2}$, $q = t_{k-1}$, $e = x_q$, $d = x_n$ (which implies $x = (x_1, \dots, x_p, \underbrace{e, \dots, e}_{q-p}, \underbrace{d, \dots, d}_{n-q})$). Two cases may occur.

- (a) If $\sum_{i=1}^q \delta_i x_i \leq \sum_{i=1}^q \delta_i y_i$, let us say

$$\sum_{i=q+1}^n \delta_i (x_i - \epsilon) = \sum_{i=q+1}^n \delta_i y_i$$

for some $\epsilon \geq 0$, then (1) and the inductive hypothesis applied to

$$(d - \epsilon, \dots, d - \epsilon) \text{ and } (y_{q+1}, \dots, y_n) \text{ with sequence } (\delta_{q+1}, \dots, \delta_n)$$

and to

$$(x_1, \dots, x_q) \text{ and } (y_1, \dots, y_q) \text{ with sequences } \delta^1, \dots, \delta^{k-1}$$

respectively implies

$$\sum_{i=q+1}^n \beta_i x_i \geq \sum_{i=q+1}^n \beta_i y_i \text{ and } \sum_{i=1}^q \beta_i x_i \geq \sum_{i=1}^q \beta_i y_i$$

respectively, where equality can only hold simultaneously in case $y = x$. Therefore the proof is finished.

- (b) If $\sum_{i=1}^q \delta_i x_i \geq \sum_{i=1}^q \delta_i y_i$, let us say $\sum_{i=1}^q \delta_i x_i - \epsilon = \sum_{i=1}^q \delta_i y_i$ for some $\epsilon > 0$, then then we come up with

$$\sum_{i=1}^p \delta_i x_i + \sum_{i=p+1}^q \delta_i (e - \epsilon / \sum_{i=p+1}^q \delta_i) = \sum_{i=1}^q \delta_i y_i$$

and

$$\sum_{i=q+1}^n \delta_i (d + \epsilon / \sum_{i=q+1}^n \delta_i) = \sum_{i=q+1}^n \delta_i y_i.$$

The inductive hypothesis and (1) imply

$$\sum_{i=1}^q \beta_i y_i \leq \sum_{i=1}^p \beta_i x_i + \sum_{i=p+1}^q \beta_i (e - \epsilon / \sum_{i=p+1}^q \delta_i) \quad (5.8)$$

and

$$\sum_{i=q+1}^n \beta_i y_i \leq \sum_{i=q+1}^n \beta_i (d + \epsilon / \sum_{i=q+1}^n \delta_i), \quad (5.9)$$

thus it remains to show that

$$\sum_{i=q+1}^n \frac{\beta_i}{\sum_{j=q+1}^n \delta_j} < \sum_{i=p+1}^q \frac{\beta_i}{\sum_{j=p+1}^q \delta_j} \quad (5.10)$$

holds true. As (5.10) can be rewritten as

$$\sum_{i=q+1}^n \beta_i \cdot \sum_{j=p+1}^q \delta_j < \sum_{i=p+1}^q \beta_i \cdot \sum_{j=q+1}^n \delta_j$$

it is sufficient to verify

$$\beta_{q+1} \cdot \max_{j=p+1, \dots, q} \delta_j < \beta_q \cdot \min_{j=q+1, \dots, n} \delta_j$$

which is true by definition of β .

q.e.d.

Lemma 5.2 *For every balanced collection $\mathcal{S} \subseteq 2^N$ of coalitions with $|N| = n \in \mathbb{N}$ there is a sequence $(\delta_S)_{S \in \mathcal{S}}$ of balancing coefficients satisfying $\max_{S, T \in \mathcal{S}} \delta_S / \delta_T \leq c(n)$.*

Proof: Let \mathcal{S} be a balanced collection and assume without loss of generality that $\emptyset \notin \mathcal{S}$. Then $\mathcal{S} = \bigcup_{i=1}^k \mathcal{S}^i$ for some minimal balanced collections \mathcal{S}^i , $i = 1, \dots, k$, with balancing coefficients $(\delta_S^i)_{S \in \mathcal{S}^i}$ which are uniquely determined. For $i = 1, \dots, k$ define $\alpha_i = 1/\min_{S \in \mathcal{S}^i} \delta_S^i$. Observe that $(\delta_S)_{S \in \mathcal{S}}$ defined by

$$\delta_S = \frac{\sum_{i=1}^k \delta_S^i \cdot \alpha_i}{\sum_{i=1}^k \alpha_i}$$

for $S \in \mathcal{S}$ (where $\delta_S^i = 0$ by convention, if $S \notin \mathcal{S}^i$) is a sequence of balancing coefficients which possesses the desired property. q.e.d.

Proof of Theorem 3.6: It is sufficient to prove the result concerning the prenucleolus, because the antinucleolus can be treated analogously by replacing a game by its dual. In order to apply the preceding lemmata, let (N, v) be a game, $c > c(n)$, $\nu = \nu(N, v)$ be the prenucleolus, and $z \in X^*(N, v)$ be such that

$$U_{pc}(z, v) \geq U_{pc}(\nu, v).$$

It remains to show that $z = \nu$ holds true. By Corollary 1.4 we can assume that z is Pareto optimal, because U_{pc} reduces inequality. Let S^1, \dots, S^{2^n} be an ordering of the set of coalitions, i.e. $\{S^i \mid i = 1, \dots, 2^n\} = 2^N$, such that the arising vector of satisfactions w.r.t. the prenucleolus is nondecreasing, whereas the arising vector of satisfactions w.r.t. z is nondecreasing on constant parts of the other vector, i.e.

$$f(S^i, \nu, v) \leq f(S^{i+1}, \nu, v) \tag{5.11}$$

$$f(S^i, z, v) \leq f(S^{i+1}, z, v) \quad , \text{ if } f(S^i, \nu, v) = f(S^{i+1}, \nu, v) \tag{5.12}$$

for $i = 1, \dots, 2^n - 1$. Define

$$\begin{aligned} x &= \left(f(S^1, \nu, v), \dots, f(S^{2^n}, \nu, v) \right), \\ y &= \left(f(S^1, z, v), \dots, f(S^{2^n}, z, v) \right) \in \mathbb{R}^{2^n}, \end{aligned}$$

and $0 = t_0 < t_1 < \dots < t_k = 2^n$ by

$$x_i = x_j \text{ for } t_{r-1} < i, j \leq t_r \text{ and } r = 1, \dots, k \tag{5.13}$$

and

$$x_{t_r} < x_{t_{r+1}} \text{ for } r = 1, \dots, k-1. \tag{5.14}$$

Kohlberg's (1971) result shows that the sets $\mathcal{S}^r = \{S^1, \dots, S^{t_r}\}$ are balanced. According to Lemma 5.2 there are balancing coefficients $(\delta_i^r)_{i=1}^{t_r}$ for \mathcal{S}^r satisfying $\delta_i^r/\delta_j^r \leq c(n)$ for $i, j \in \{1, \dots, t_r\}$. Pareto optimality of z and Lemma 5.1 directly imply that $x = y$, thus $\nu = z$ is true. q.e.d.

With the help of Theorem 2.2 (and its proof) of Sudhölter (1997) Theorem 4.4 can be verified using precisely the same technic as proposed in the preceding paragraph. Instead of presenting a detailed proof we only recall one characterization of the modified nucleolus in what follows.

A set $\mathcal{T} \subseteq 2^N \times 2^N$ is called **m-balanced** if $\{1_S + 1_T \mid S, T \in \mathcal{T}\}$ is balanced. The following assertion is the content of Sudhölter's (1997) Theorem 2.2.

A preimputation x of a game (N, v) coincides with the modified nucleolus $\psi(v)$, if and only if

$$\mathcal{T}(x, \alpha, v) = \{(S, T) \in 2^N \times 2^N \mid f(S, x, v) - f(T, x, v) \leq \alpha\}$$

is m -balanced for $\alpha \in \mathbb{R}$ such that $\mathcal{T}(x, \alpha, v) \neq \emptyset$.

If $\mathcal{T}(x, \alpha, v)$ is m -balanced, then there is a balanced set of coalitions $\mathcal{S} \subseteq 2^{N \cap N^*}$, where N^* is a disjoint copy of N , such that for every sequence $(\delta_S)_{S \in \mathcal{S}}$ of balancing coefficients for \mathcal{S} there is a balancing sequence $(\delta_{(S, T)})_{(S, T) \in \mathcal{T}}$ which arises from the initial sequence by taking components and sums of two components only (up to a normalization). This assertion is content of the proof of Theorem 2.2 and shows that balancing coefficients of m -balanced collections can be chosen in such a way that their quotients are bounded by $2c(2n)$ by Lemma 5.2.

The proof of Theorem 4.4 can be completed analogously to that of Theorem 3.6 by interchanging the rôles of ‘balancedness’ by ‘ m -balancedness’, ‘prenucleolus’ by ‘modified nucleolus’, and ‘ U_{pc} ’ by ‘ \tilde{U}_c ’.

References

- [1] Atkinson AB (1970) On the measurement of inequality. *J. Economic theory* 2, 244-263
- [2] Derks JJM and Haller HH (1995) Null players out? Report M95-02, Department of Mathematics, University of Limburg, Maastricht, The Netherlands
- [3] Dutta B and Ray D (1989) A concept of egalitarianism under participation constraints. *Econometrica* 57, 615-635
- [4] Kohlberg E (1971) On the nucleolus of a characteristic function game. *SIAM Journal Appl. Math.* 20, 62-66
- [5] Kohlberg E (1972) The nucleolus as the solution of a minimization problem. *SIAM Journal Appl. Math.* 23, 34-39
- [6] Kolm SC (1966) The optimal production of the social justice. In ‘Colloques Internationaux du Centre National de la Recherche Scientifique, Biarritz, 2-9 September 1966’
- [7] Maschler M (1992) The bargaining set, kernel, and nucleolus: A survey. In R.J. Aumann and S. Hart, Eds., *Handbook of Game Theory 1*, Elsevier Science Publishers B.V., Amsterdam, The Netherlands, 591-665
- [8] Milnor JW (1952) Reasonable outcomes for n -person games. RM 916, The RAND Corporation, Santa Monica, CA
- [9] Moulin H (1988) *Axioms of cooperative decision making*. Cambridge University Press, New York, USA
- [10] Peleg B (1965) An inductive method for constructing minimal balanced collections of finite sets. *Naval Research Logistics Quarterly* 12, 155-162

- [11] Peleg B (1972) Topological properties of the efficient point set. *Proceedings of the American Mathematical Society* 35, 531-536
- [12] Schmeidler D (1969) The nucleolus of a characteristic function game. *SIAM J. Appl. Math.* 17, 1163-1170
- [13] Shapley LS (1953) A value for n -person games. in: H. Kuhn and A.W. Tucker, eds., *Contributions to the Theorie of Games II*, Princeton University Press, pp. 307-317
- [14] Sudhölter P (1996a) The modified nucleolus as canonical representation of weighted majority games. *Mathematics of Operations Research* 21, 734-756
- [15] Sudhölter P (1996b) Star-shapedness of the kernel for homogeneous games. *Mathematical Social Sciences* 32, 179-214
- [16] Sudhölter P (1997) The modified nucleolus: properties and axiomatizations. To appear in the *Int. Journal of Game Theory*
- [17] Von Neumann J and Morgenstern O (1944) *Theory of games and economic behavior*. Princeton University Press, Princeton, NJ

Nucleoli as Maximizers of Collective Satisfaction Functions: Erratum¹

by Peter Sudhölter and Bezalel Peleg

Theorems 2.9 and 2.10 in Sudhölter and Peleg (1998) are incorrect. Indeed, the following examples show that the maximal satisfaction solution \mathcal{M} does not satisfy NPP and, thus, does not satisfy REAS.

Example 1: Let $N = \{1, 2, 3, 4\}$

(1) Let (N, v) be defined by

$$v(S) = \begin{cases} 0, & \text{if } |S \cap \{2, 3, 4\}| \leq 2 \\ 4, & \text{if } |S \cap \{2, 3, 4\}| = 3 \end{cases}.$$

Then player 1 is a nullplayer and $(1, 1, 1, 1) \in \mathcal{M}(v)$, which can be checked by applying Theorem 2.2 of Sudhölter and Peleg (1998). This example shows that \mathcal{M} does not satisfy NPP and that it does not satisfy the second inequality required by REAS.

(2) Let (N, v) be defined by

$$v(S) = \begin{cases} 0, & \text{if } |S \cap \{2, 3, 4\}| \leq 1 \\ 8, & \text{if } |S \cap \{2, 3, 4\}| \geq 2 \end{cases}.$$

Then player 1 is a nullplayer and $(-1, 3, 3, 3) \in \mathcal{M}(v)$, which can be checked again by applying Theorem 2.2. This example shows that \mathcal{M} does not satisfy the first inequality required by REAS.

Remark 2: All other results of Sudhölter and Peleg (1998) remain valid. However, in the proof of Theorem 2.12 the reference “Theorem 2.10” has to be replaced by “the proof of Theorem 2.6”. Moreover, in the first paragraph after Theorem 3.2, “ $-1 \leq v(S \cup \{i\}) - v(S) \leq 1$ for $S \subseteq N \setminus \{i\}$ ” has to be replaced by “ $-1 \leq x_i \leq 1$ for $x \in \mathcal{M}(v)$ ”. Finally, in the same paragraph as well as in the first sentence of the proof of Theorem 4.2, “Theorem 2.10” and “ $\{x \in X(v) \mid x \text{ is reasonable}\}$ ” have to be replaced by “Theorem 2.6” and “ $\mathcal{M}(v)$, which is bounded”.

In spite of the fact that the maximal satisfaction solution does not satisfy the nullplayer property it may still be of some use. Indeed, the bargaining set also does not satisfy the nullplayer property and, nevertheless, it plays a very important rôle in the theory of cooperative games.

We are grateful to J. Arin and V. Feltkamp for pointing out the foregoing mistake and giving an example similar to Example 1 (1).

Reference

Sudhölter P, Peleg B (1998) Nucleoli as maximizers of collective satisfaction functions. *Social Choice and Welfare* 15: 383-411

¹This Erratum is published in *Social Choice and Welfare* 17, 379-380.